

PROGRAMMABLE TAPE APPLICATOR AFTD-1

- 2 separately programmable taping heads;
- programming : PLC with LCD menu display;
- 10 jobs memories
- suitable for a large variety of tapes;
- speed : 20M/min (fixed);
- max document thickness : 2-3mm;
- min document stiffness : 250gr/M² (150gr/M² with some limitations);
- document width : from 5 to 70cm;
- document length : from 5 to 39cm with delivery tray, 150cm without using the delivery tray;
- tape width : from 5 to 20mm;
- tape roll core : 3" 76mm;
- max tape roll diameter : 30cm;
- max taping strips/head and document : 4 (see below);
- document transport method : conveyor belt;
- safety stop switch;
- requires 8 Bar compressor (not included);
- power supply : 220-230V 50Hz 180W;
- dimensions (LxWxH) : 110x100x150cm;
- delivered with stand;
- CE compliance

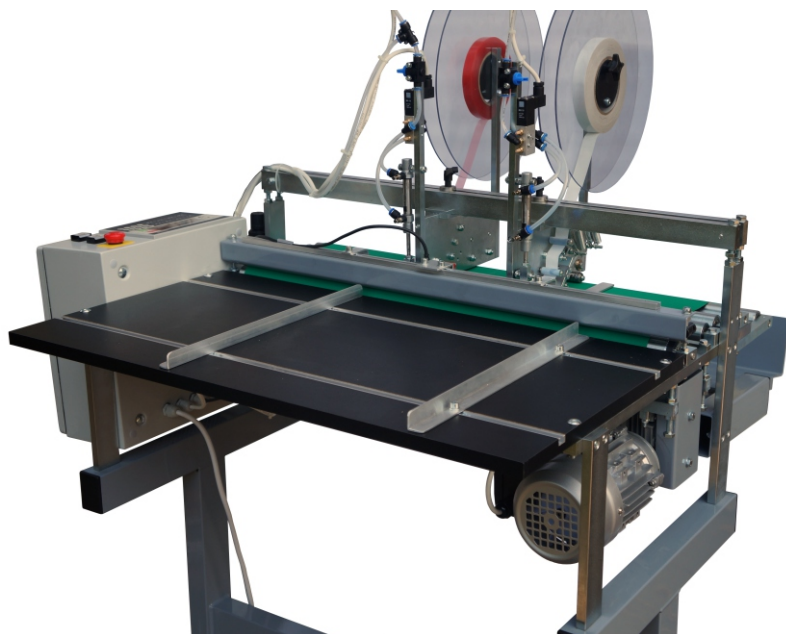

This machine can be modified and adapted according to the customer needs.

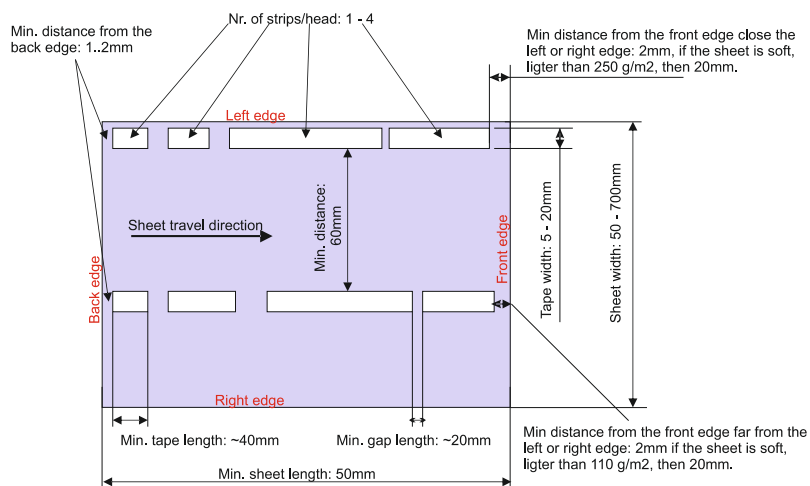

The cutting at the beginning and at the end of the tap has a zigzag pattern not a straight edge.

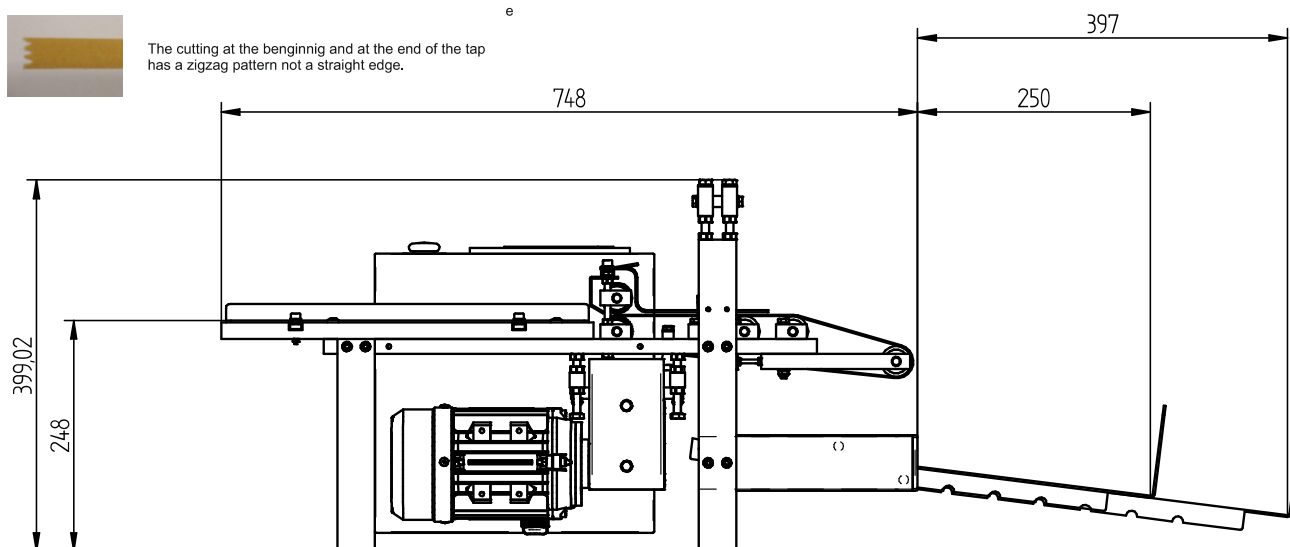

ABILITY ACCESS ^{sa} _{nv}
 Chaussée de Wavre 318,
 B-1390 GREZ-DOICEAU, BELGIUM
 Tel +32 (0)10 227 556 Fax +32 (0)10 227 910
 a2yes@edpnet.be www.a2yes.com